

# **An Explanation of the Electron's Mass by the Energy of its Fields**

Claus W. Turtur  
University of Applied Sciences Braunschweig- Wolfenbüttel  
Salzdahlumer Straße 46 / 48  
GERMANY - 38302 Wolfenbüttel  
E-mail.: c-w.turtur@fh-wolfenbuettel.de

## **Abstract**

It is demonstrated, that the mass of the electron can be completely explained by the energy of its fields, if we take all of the fields into account, the electric field as well as the magnetic field. But this explanation leads to a new electron's radius different from the classical value, namely  $r_0 = 4.9 \cdot 10^{-13}$  Meter .

Based on this explanation, it seems sensible, to calculate the mass of all particles in such way. For that it would be necessary to classify the fundamental interactions as causative (electromagnetic, strong and weak) and consecutive (gravitation) interactions. The fields of the causative interactions of each particle then contains exactly the energy to explain its mass and by that the appearance of the consecutive interaction.

## **Structure of the Article:**

1. Introduction / Basic Idea
2. The failure of previous approaches
3. The electron as a non-rigid field source
4. Discussion of the results
5. Continuative considerations
6. Literature

## **1. Introduction / Basic idea:**

The attempt to explain the origin of the mass of elementary particles by the energy of interactions is widely spread. For instance, the example of the explanation of the mass of hadrons on the basis of binding- energy keeping quarks together is well known (see for instance [PER 91] or [FRA 99]). But in such type of calculations the rest mass of the quarks has to be included. If we follow the thought of mass- energy- equivalence consequently to the very end, we want to explain the mass of elementary particles completely by the energy contained of their fields.

In this sense, we regard elementary particles as objects which produce some fields, for instance a field of Coulomb- interaction, or weak interaction or strong interaction, as the case may be even more than one of these fields at the same time. Each of these fields contains some given amount of energy – and exactly these energies should be able to explain the total mass of the particular elementary particle. Each particle can than be understood just as a source of fields in space. In the case of binding- energy we observe comparatively high density of energy in the volume very

close to the bonded particles, but their fields compensate each other with increasing distance from the bonded field centres.

In this aspect, nature of all mass is just the manifestation of interaction- field- energy. Elementary particles are field- centres. In a quantum- or field- theoretical view, mass can be understood as manifestation of the produced interaction quanta.

Formulated the other way around: If we know the fields produced by a particle, we can trace back to its mass. Also this approach is not new. For instance Feynman tells about different efforts to explain the mass of the electron by its electric field (see [FEY 91]). He comes to the conclusion, that electrodynamics runs into difficulties within this attempt. The problem is the same with regard to classical electrodynamics following Maxwell, as well as with modern quantum electrodynamics. Feynman even describes some attempts to modify Maxwell's Theory, which none of them got free of problems and contradictions (see especially Chapter 28-5 in [FEY 91]).

In this work here it will be demonstrated, that it is indeed possible to explain the whole mass of the electron completely by its field's energy. This can already be successfully be done on the basis of Maxwell's classical electrodynamics. The crucial point is the consideration of **all** fields of the electron ! Thus it is not enough to take only the electrostatic energy of the electron into account, but we have also to include the magnetic field and its energy into our calculations. Putting both fields into the calculation (what Feynman did not do), we can easily explain the electron's mass as shown on the following next pages. (In our first approach here, we regard the field of the weak interaction as comparatively negligible.)

It shall be annotated, that in the case of some of the elementary particles, the Higgs-boson's contribution to the mass is under discussion ([HIG 64]). But up to now, the existence of the Higgs- Boson is not experimentally verified. Perhaps the interaction-field based explanation will bring this understanding in a direct and natural way without the necessity to postulate new particles just to find an explanation for something which can not be understood otherwise.

Before starting with model- calculations, we will consider a short remark about the application of classical physic's formulas:

Of course there are limitations of classical approaches with respect to the dimensions of elementary particles. Consequently we restrict the use of classical formulas to such which are valid down to microscopic dimensions - as for instance Coulomb's law. Microscopic formulas which have been developed especially for microscopic dimensions are naturally not affected by this restriction.

## **2. The failure of previous approaches**

With regard to previous approaches (see for instance [FEY 91]), the electron can be seen as an electrically charged sphere with the charge distributed homogeneously on its surface. Approaches for the explanation of the electron's mass on the basis of the electrostatic field, discussed in [FEY 91], lead to contradictions in a way, that theory will not be self consistent anymore. There are several trials to solve this inconsistency – for instance the assumption of Poincaré- tensions within the spherical surface of the electron. These tensions require the existence of forces and elongations.

Finally all such approaches lead to the necessity of an alteration of the theory of electrodynamics, but even this alteration will not get rid of the above mentioned contradictions.

Feynman reports about several trials to solve this problem, which all remained unsuccessful up to now. The difficulties can also not be disposed by the use of quantum- electrodynamics. On the basis of this knowledge, we do not expect any advantage when using non-classical physics instead of classical.

All these approaches reported above are restricted to the energy of the electrostatic field and this is their problem. As a matter of fact, the electrostatic field is not the only one, which is produced by the electron. If we regard the electron as a sphere, charged on its surface (together with Feynman and others), this sphere will cause an electrostatic field because of its charge. But it will additionally cause a magnetic field because of its spin ! For the calculation of the fields' energy we have to take both contributions into account, the electrostatic one as well as the magnetic one. This is what is done in the article presented here. And this is the only necessity in order to get rid of the problems and contradictions reported above.

By the way, it should be mentioned, that we firstly begin with an approach that does not already describe the final solution of the problem, but that will be necessary to prepare the understanding of the final solution. Only very slight alterations will be necessary (in chapter 3) to come from this first approach to the final solution.

#### Part 1. The electrostatic energy:

In the inside of the electron (as a sphere charged on its surface) the electrostatic field is ZERO, in the outside the field follows Coulomb's law. For our purpose, the calculation of the absolute value of this field is sufficient:

$$|\vec{E}| = \frac{q}{4\pi\epsilon_0 r^2} \quad \text{where} \quad q = 1.602 \cdot 10^{-19} \text{ C} \quad (\text{equ.01})$$

$$\epsilon_0 = 8.854 \cdot 10^{-12} \frac{\text{C}^2}{\text{Jm}} \quad \text{see}[9]$$

**r = distance from the center of the electron**

From the square of the electrostatic field, we derive its energy- density, this is a scalar- field as a function from the distance to the center of the electron:

$$u_{\text{el,stat}} = \frac{\epsilon_0}{2} |\vec{E}|^2 = \frac{q^2}{32\pi^2 \epsilon_0 r^4} \quad (\text{in the exterior of the electron}) \quad (\text{equ.02})$$

see[6]

Integration of this energy-density over the volume of the whole three-dimensional space ( $\mathbb{R}^3$ ) will lead us to the total energy of the electrostatic field, where contributions only from the outside of the electron have to be taken into account:

$$W_{\text{elektr}} = \int_{\mathbb{R}^3} u_{\text{el,stat}} dV = \int_0^{2\pi} \int_0^{\pi} \int_{r_0}^{\infty} \frac{q^2}{32\pi^2 \epsilon_0 r^4} \cdot r^2 \sin\vartheta \, dr \, d\vartheta \, d\varphi = \frac{q^2}{8\pi\epsilon_0 r_0} \quad (\text{equ.03})$$

**where  $r_0$  = radius of the homogeneously charged spherical electron**

Remark:

According to the calculation known before this article appeared, putting the electron's mass into equation 03, we would get the definition of the classical electron's radius ([COD 98]:  $r_0 = 2.818 \cdot 10^{-15} \text{ m}$ ) with all its contradictions and inconsistencies mentioned. But now we want to take additionally the magnetic field of the electron into account, which can be derived from its spin.

Part 2. The magnetic energy:

We will keep the appearance of the electron as a spherical shape with the electrical charge being distributed homogeneously on its surface. Because of its spin, the sphere rotates with an angular speed  $\omega$  and thereby produces a magnetic field, whose field strength can be calculated by Biot-Savart's law ([ABE 71/81], equation 4). Even though the very first pre-approach reported now will not come finally to a fully consistent model, a very short outline of this pre-approach is given in order to prepare the fully consistent explanation following in chapter 3. The final consistent solution is built directly on this first pre-approach with minimum of changes necessary.

Let us introduce the following abbreviations:

$r, \vartheta, \varphi$  for the position of the points on the electron's surface (in spherical coordinates), these are the positions where the charge is located. Therefore we use lower case letters without index.

$R_0, \Theta_0, \Phi_0$  for the position of the space point (in spherical coordinates), this is the (variable) point, at which the field strength shall be determined. Therefore we use upper case letter with index "0".

The nomenclature of spherical coordinates is chosen according to the standard (see figure 1). The axis of rotation of the electron is the z-axis.

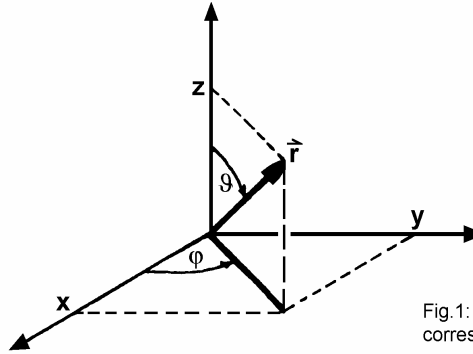

Fig.1: Use of the spherical coordinates corresponds to the usual nomenclature

Biot- Savart's law says:

$$\vec{H}_{in} = q_{in} \cdot \frac{\vec{v}_{in} \times (\vec{s}_{in} - \vec{r})}{4\pi \cdot |\vec{s}_{in} - \vec{r}|^3} \quad \left( \text{The index "in" represents an infinitesimally small portion of the electron's surface and charge.} \right)$$

( equ.04 )

where  $q_{in}$  = charge of the infinitesimal fraction of the electron

$\vec{s}_{in}$  = position of the infinitesimal fraction of the electron

$\vec{v}_{in}$  = velocity of the infinitesimal fraction of the electron

$\vec{r}$  = position of the point of determination of the magnetic field

, thus  $\vec{s}_{in} = \begin{pmatrix} r_0 \cdot \sin \vartheta \cdot \cos \varphi \\ r_0 \cdot \sin \vartheta \cdot \sin \varphi \\ r_0 \cdot \cos \vartheta \end{pmatrix}$  as well as  $\vec{v}_{in} = \begin{pmatrix} -\omega r_0 \cdot \sin \vartheta \cdot \sin \varphi \\ \omega r_0 \cdot \sin \vartheta \cdot \cos \varphi \\ 0 \end{pmatrix}$

and  $\vec{r} = \begin{pmatrix} R_0 \cdot \sin \Theta_0 \cdot \cos \Phi_0 \\ R_0 \cdot \sin \Theta_0 \cdot \sin \Phi_0 \\ R_0 \cdot \cos \Theta_0 \end{pmatrix}$  ( equs .05 a-c )  
(with rotation of the electron around the z-axis)

Integration of the infinitesimal fields  $\vec{H}_{in} = d\vec{H}$  connected with the infinitesimal surface- elements according to equation 04 as surface integral along the spherical

surface of the electron ([BRO 79],[SMI 81]) leads us to the total magnetic field produced at the space point  $\vec{r}$  :

$$\vec{H}_{\text{tot}} = \int_0^{2\pi} \int_0^{\pi} \frac{\sigma}{4\pi} \left[ (r_0 \sin \vartheta \cos \varphi - R_0 \sin \Theta_0 \cos \Phi_0)^2 + (r_0 \sin \vartheta \sin \varphi - R_0 \sin \Theta_0 \sin \Phi_0)^2 + (r_0 \cos \vartheta - R_0 \cos \Theta_0)^2 \right]^{-\frac{3}{2}} \cdot \begin{pmatrix} -\omega r_0 \sin \vartheta \sin \varphi \\ -\omega r_0 \sin \vartheta \cos \varphi \\ 0 \end{pmatrix} \times \begin{pmatrix} r_0 \sin \vartheta \cos \varphi - R_0 \sin \Theta_0 \cos \Phi_0 \\ r_0 \sin \vartheta \sin \varphi - R_0 \sin \Theta_0 \sin \Phi_0 \\ r_0 \cos \vartheta - R_0 \cos \Theta_0 \end{pmatrix} r_0^2 \sin \vartheta \, d\vartheta \, d\varphi \quad (\text{equ.06})$$

, where  $\sigma$  = density of charge per area

$$\text{, therefore charge } q = \int \sigma \, dA = \int_0^{2\pi} \int_0^{\pi} \sigma \cdot r_0^2 \sin \vartheta \, d\vartheta \, d\varphi \quad (\text{equ.06b})$$

Integration was carried out numerically by iteration and will bring the following approximative result. (Results received from iteration are marked with a symbol “ $\approx$ ” instead of the “=”):

$$\vec{H}_{\text{ext}} \approx -C_1 \cdot \frac{\omega}{\omega_0} \cdot \frac{r_0^2}{R_0^3} \cdot \begin{pmatrix} \sin(2\Theta_0) \cdot \cos \Phi_0 \\ \sin(2\Theta_0) \cdot \sin \Phi_0 \\ \cos(2\Theta_0) + \frac{1}{3} \end{pmatrix} \quad \text{in the exterior of the electron} \quad (\text{equ.07})$$

$$\vec{H}_{\text{int}} \approx -C_1 \cdot \frac{\omega}{\omega_0} \cdot \frac{1}{r_0} \cdot \begin{pmatrix} 0 \\ 0 \\ \frac{4}{3} \end{pmatrix} \quad \text{in the interior of the electron} \quad (\text{equ.08})$$

with the constants  $C_1 = 1$  Ampere

$$\text{and } \omega_0 = \frac{\pi}{2} \cdot 10^{20} \text{ Hz}$$

Of course the magnetic field is a vector field again, but its energy density is  $u_{\text{magn}} = \frac{\mu_0}{2} |\vec{H}|^2$  and thus also a scalar field who's integration over the complete field's volume (this is the whole space  $\mathbb{R}^3$ ) leads us to the total energy of the magnetic field. This integration can be performed analytically, but has to be done separately for the inside and the outside of the electron. The result is (see [ABE 71/81]):

$$W_{\text{magn}_{\text{int}}} = \int_0^{2\pi} \int_0^{\pi} \int_0^{r_0} \frac{\mu_0}{2} \cdot |\vec{H}_{\text{int}}|^2 \cdot R_0^2 \sin \Theta_0 \, dR_0 \, d\Theta_0 \, d\Phi_0 = \dots \approx \frac{32\pi}{27} \mu_0 C_1^2 \cdot \frac{\omega^2}{\omega_0^2} \cdot r_0$$

$$W_{\text{magn}_{\text{ext}}} = \int_0^{2\pi} \int_0^{\pi} \int_{r_0}^{\infty} \frac{\mu_0}{2} \cdot |\vec{H}_{\text{ext}}|^2 \cdot R_0^2 \sin \Theta_0 \, dR_0 \, d\Theta_0 \, d\Phi_0 = \dots \approx \frac{16\pi}{27} \mu_0 C_1^2 \cdot \frac{\omega^2}{\omega_0^2} \cdot r_0$$

$$\Rightarrow W_{\text{magn}} \approx \frac{48\pi}{27} \mu_0 C_1^2 \cdot \frac{\omega^2}{\omega_0^2} \cdot r_0 \quad \text{for the total energy contained in the magnetic field of the electron} \quad (\text{equ.09})$$

, whereas  $\mu_0 = 4\pi \cdot 10^{-7} \frac{\text{Vs}}{\text{Am}}$  see [KOH 85]

As can be seen in the equations 03 and 09, the total energy sum of the electrostatic and magnetic field is:

$$W_{\text{tot}} = W_{\text{elektr}} + W_{\text{magn}} \approx \frac{q^2}{8\pi \epsilon_0 r_0} + \frac{48\pi}{27} \mu_0 C_1^2 \cdot \frac{\omega^2}{\omega_0^2} \cdot r_0 = m_0 c^2 \quad (\text{equ.10})$$

see[EIN 65]  Aim of our work is the explanation of the mass of the electron.

This energy contains a portion monotonously increasing with  $r_0$  and another portion monotonously decreasing with  $r_0$ . But in equation 10 two unknown sizes appear, namely  $\omega$  und  $r_0$ . In order to find the solution we must additionally take a second equation, which we find from the magnetic moment of the electron, as following:

We begin with the magnetic moment  $\mu$  of a single conductor loop with the cross-sectional area  $\tilde{A}$ , and a current  $I$  flowing through this loop, as known by

$$\mu = \tilde{A} \cdot I \quad (\text{Glg.11})$$

We will now subdivide the sphere "electron" into infinitesimal conductor loops according to fig.2:

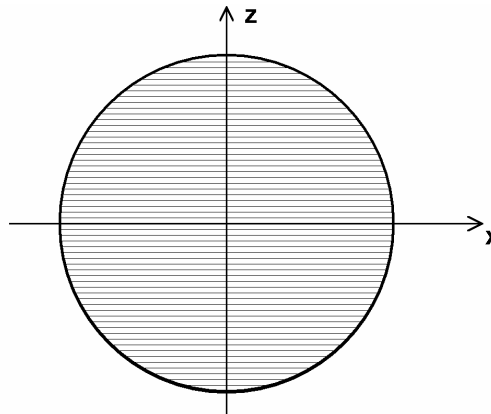

Fig.2: Illustration of the segmentation of the electron into infinitesimal conductor loops. (The electron rotates around the z-axis.)

The magnetic moment of the whole rotating sphere is then:

$$\mu = \int \tilde{A}(\Theta_0, \Phi_0) \frac{\sigma(\Theta_0, \Phi_0)}{T} dA \quad , \text{ which can again be solved as a surface integral} \quad (\text{equ.12})$$

with  $\tilde{A}(\Theta_0, \Phi_0) = \pi r_0^2 \cdot \sin^2 \Theta_0 =$  **cross-sectional area of each single conductor loop**

but  $dA =$  **Integration over the surface of the electron according to equ.06b**

as well as  $\sigma(\Theta_0, \Phi_0) = \frac{q}{4\pi r_0^2} =$  **density of charge per area on the surface of the electron**

and  $I = \int \frac{\sigma(\Theta_0, \Phi_0)}{T} dA = \frac{\text{total charge}}{\text{time}} =$  **electric current**

and  $T = \frac{2\pi}{\omega} =$  **duration of circulation**

$$= \int_0^{2\pi} \int_0^\pi \pi r_0^2 \sin^2 \Theta_0 \cdot \frac{q}{4\pi r_0^2} \cdot \frac{1}{T} \cdot r_0^2 \sin \Theta_0 d\Theta_0 d\Phi_0$$

$$= r_0^2 \cdot \frac{q}{T} \cdot \frac{4}{3} \cdot 2\pi = \frac{q\hbar}{2m} \quad (\text{equ.13})$$

see [KÖP 97] The total magnetic moment must be equal if we firstly disregard correction from Quantum-electrodynamics in the moment.

$$\Rightarrow \omega = \frac{2\pi}{T} = \frac{3\hbar}{8mr_0^2} \quad (\text{equ.14})$$

Now we got the two necessary equations to calculate  $\omega$  und  $r_0$ , namely equation 10 and equation 14. The result is:

$$r_0 = 1.92 \cdot 10^{-14} m$$

$$\omega = 1.18 \cdot 10^{23} \text{ sec}^{-1}$$

A calculation of the circular speed of the equator directly displays the problem:

$$v = \omega r_0 \approx 22.6 \cdot 10^8 \frac{m}{s} \quad (\text{equ.15})$$

This is incompatible with the theory of relativity !

Even a much more simple consideration shows the problem:

If we put the classical electron's radius of  $r_0 = 2.8 \cdot 10^{-15} m$  [COD 98] into equation 14 we would come to

$$v = \omega \cdot r_0 = \frac{3\hbar}{8mr_0} = 1.55 \cdot 10^{+10} \frac{m}{s} \quad (\text{equ.16})$$

for the speed of the equator. The contradiction to the theory of relativity is even more distinct than in equation 15.

The result shows the problem:

If we include both fields into our calculation, the electrostatic as well as the magnetic, we can explain the mass of the electron completely by its fields, but the resolution is in contradiction with the theory of relativity up to now. On the other hand a restriction of the speed of the equator to the speed of light would bring us to the problem, that the magnetic field would not be strong enough to allow an explanation of the electron's mass only by its fields.

Of course we could now conclude to the failure of classical physics in microscopic dimensions. But facts are not that simple, as we will see soon. In order to get free of contradictions, we want to reflect all assumptions made up to now, and to check which of them are acceptable and which can be rejected. We have the following:

- (a.) The mass of the electron can be explained completely by the energy of its fields.
- (b.) The magnetic moment of the electron is given by Bohr's Magneton.
- (c.) The laws of Coulomb and Biot-Savart are valid also for very short distances, as used in our calculations.
- (d.) The electron can be regarded as a rigid sphere, with the electrical charge being located on its surface, gyrating with a constant angular speed.

Assumption (a.) is the very basic postulate of this work, so it is useless to drop this.

Assumption (b.) is correct except for quantum-electrodynamical corrections. But these corrections are for sure not large enough to solve our contradictions ([FEY 88]).

Assumption (c.) is not to be given up, because it is well known, that at least down to the extent  $10^{-18} m$  there is no doubt on Coulomb's law (except for shielding of the electron's electrical charge by itself because of vacuum polarisation – this effect is also not large enough to explain the problems in equation 15 and equation 16).

Consequently the only possibility we have, is to doubt on assumption (d.). This assumption contains several details:

- The spherical shape of the electron and the spherical charge-distribution

We do not withdraw this assumption, because up to now we do not know about any experimental hints that might contradict to it. And there is no hint, that a different shape is more likely.

- The distribution of the charge is on the surface of the electron

This assumption allows doubt, but putting the charge more into the inside of the electron would decrease the magnetic field, caused by the spin. This would be the opposite of what we are searching for, so it would be of no use.

- The rigour of the sphere and constance of the angular speed.

If we disclaim this assumption, we can for instance allow all parts of the charge (on the surface of the electron) to gyrate with an individual speed. (We will not discuss about the radiationless gyration of electric charge here, for we know that this classical principle is not transferable to microscopic physics. Besides,

the electron emanates a magnetic field, which would not exist without the gyration of the charge.) Each element of charge will then keep constant speed on its orbit, maximum the speed of light, but different elements of charge will gyrate with different angular frequencies. Electric currents and magnetic fields can then be larger compared to a rigid sphere with the equator gyrating by the speed of light and all other parts gyrating with the same angular frequency  $\omega$ .

In chapter 3 we will see that this simple assumption of a non rigid surface of the electron is already sufficient to explain the electron's mass in a surprisingly easy way exactly on the basis of the energy of its electrostatic and magnetic fields.

### 3. The electron as a non-rigid field-source

Following chapter 2, let us assume that all parts of the electron can move against each other exactly in a way, that they all adopt the speed of light. This means that all charge elements move with the same absolute speed, but charge elements with different distances to the axis of rotation move with different angular frequencies. Because we decide to accept the spherical shape of the electron, the calculation of the electrostatic field and its field-energy will be identically the same as in equ.03.

The calculation of the magnetic field will be influenced in the following way:

From the equations 04, 05a, 05b, 05c used above, only equ.05b (for  $\vec{v}_{in}$ ) is not longer applicable. The speed of the charge- elements has not any longer the absolute value of  $\omega \cdot r_0 \cdot \sin \vartheta$  but simply the absolute value of  $c =$  speed of light.

Consequently we replace equation 05b by the following equation 17

$$\vec{v}_{in} = \begin{pmatrix} -c \cdot \sin \varphi \\ +c \cdot \cos \varphi \\ 0 \end{pmatrix} \quad (\text{equ.17})$$

and perform the calculation analogously to the way described in chapter 2, now using the equations 04, 05a, 17, 05c. Then we get:

$$\vec{H}_{tot} = \frac{q}{4\pi} \int_0^{2\pi} \int_0^\pi \left[ (r_0 \sin \vartheta \cos \varphi - R_0 \sin \Theta_0 \cos \Phi_0)^2 + (r_0 \sin \vartheta \sin \varphi - R_0 \sin \Theta_0 \sin \Phi_0)^2 + (r_0 \cos \vartheta - R_0 \cos \Theta_0)^2 \right]^{\frac{3}{2}} \cdot \begin{pmatrix} -c \cdot \sin \varphi \\ +c \cdot \cos \varphi \\ 0 \end{pmatrix} \times \begin{pmatrix} r_0 \cdot \sin \vartheta \cdot \cos \varphi - R_0 \cdot \sin \Theta_0 \cdot \cos \Phi_0 \\ r_0 \cdot \sin \vartheta \cdot \sin \varphi - R_0 \cdot \sin \Theta_0 \cdot \sin \Phi_0 \\ r_0 \cdot \cos \vartheta - R_0 \cdot \cos \Theta_0 \end{pmatrix} \cdot r_0^2 \sin \vartheta \, d\vartheta \, d\varphi \quad (\text{equ.18})$$

(in analogy with equation 06)

Determination of the magnetic field as a function of the space point shows the result of a rather complicated distribution with two regions of infinity. One area of infinity is located at  $\lim_{R \rightarrow r_0}$ , where the space point comes close to the surface of the sphere.

The other infinity is observed at  $\lim_{\sin(\Theta_0) \rightarrow 0}$ , which is the region close to axis of the electron's rotation. The calculation of the field's energy from the square of the field strength will thus become an improper integral.

Here we decide to restrict ourselves to a lower estimation of the field's energy. From the field far enough away from the places of infinity we extrapolate into the surface of the sphere and into the rotation-axis. If the lower estimation of energy already gives a sufficient amount of energy to explain the mass of the electron, we can conclude that the exact energy of the field will be enough for this explanation in any case.

A result of this lower estimation of the magnetic field is displayed in the following equations 19 and 20.

$$\vec{H}_{\text{ext}} \approx \frac{r_o^2}{R_o^3} \cdot \begin{pmatrix} K_1 \cdot \sin(2\Theta_o) \cdot \cos \Phi_o \\ K_1 \cdot \sin(2\Theta_o) \cdot \sin \Phi_o \\ K_2 + K_3 \cdot \sin^2(\Theta_o) \end{pmatrix} \quad \text{with the constants}$$

$K_1 = -225.2$  Ampere  
 $K_2 = -417.9$  Ampere  
 $K_3 = +593.7$  Ampere

(equ.19)

$$\vec{H}_{\text{int}} \approx q \cdot c \cdot \begin{pmatrix} \frac{R_o^2}{r_o^4} \cdot K_4 \cdot \sin(2\Theta_o) \cdot \cos \Phi_o \\ \frac{R_o^2}{r_o^4} \cdot K_4 \cdot \sin(2\Theta_o) \cdot \sin \Phi_o \\ -\frac{1}{r_o^2} \cdot K_5 + \frac{R_o^2}{r_o^4} \cdot K_6 \cdot \sin^2(\Theta_o) \end{pmatrix} \quad \text{with the constants}$$

$K_4 = 1.273 \cdot 10^{-2}$  (without units)  
 $K_5 = 7.958 \cdot 10^{-2}$  (without units)  
 $K_6 = 3.96 \cdot 10^{-2}$  (without units)  
 $c = \text{speed of light}$

(equ.20)

Remark:

The sign "≈" is used as a symbol for the iteration and additionally expresses that we deal with a lower estimation. We evaluate the deviation of the estimated energy from its exact value as some few percent. This evaluation, is based on the ratio of the volume affected by the lower estimation and on the deviation of the approximated field relatively to the exact field. This information gives the allowance to continue with the use of equations 19 and 20.

Graphical visualizations of the fields calculated in equation 1 as well as 19 and 20 are displayed in figures 3 and 4. The little arrows represent the value of the fields in direction and strength as calculated at the startpoints of the arrows.

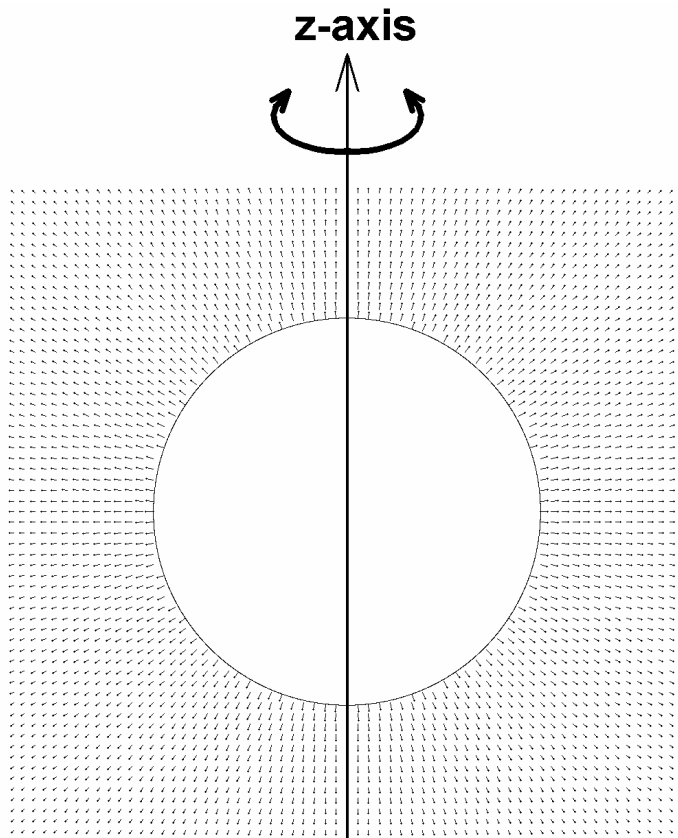

**Fig.3:**  
**Plot of the field vectors of the electrical field of the electron. The three dimensional geometry is derived from the rotation of the image around the z- axis**  
**Exact values can be calculated from equation 1.**

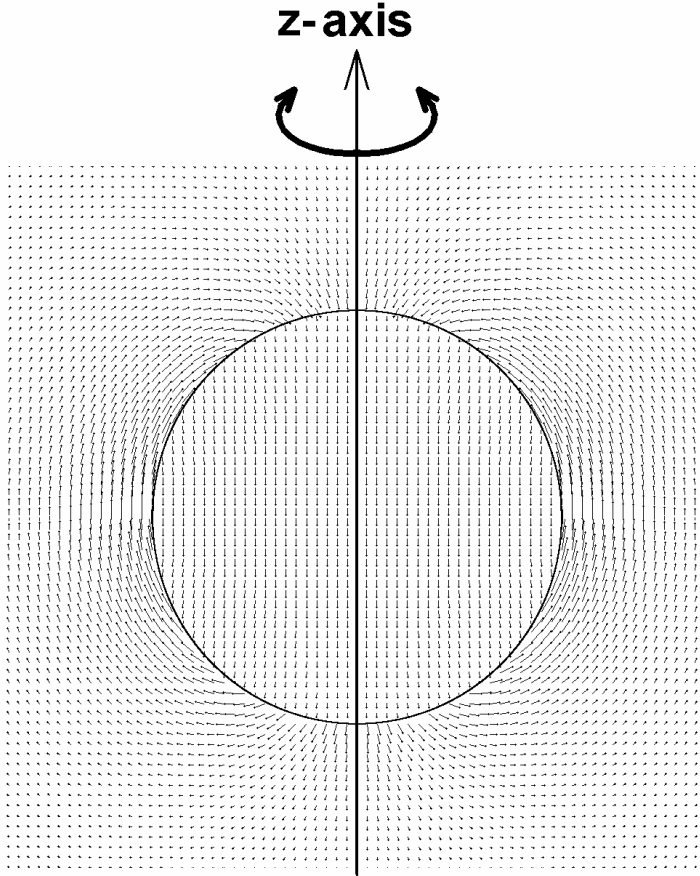

**Fig.4:**  
**Vectors of the magnetic field of the electron as a non-rigid field- source. The three dimensional field is imaginable by rotating the plot around the z- axis.**  
**Exact values of the field are given in equations 19 and 20.**

The reason for the formulation of equations 19 and 20 is, that we need a habile expression for the analytical integration over the space  $\mathbb{R}^3$  as shown in equations 21 and 22.

$$\begin{aligned}
 W_{\text{magn}_{\text{ext}}} &\cong \int \frac{\mu_0}{2} \cdot |\vec{H}_{\text{ext}}|^2 dV \\
 &= \int_0^{2\pi} \int_0^\pi \int_{r_0}^\infty \frac{\mu_0}{2} \cdot \frac{r_0^4}{R_0^6} \cdot (K_1^2 \cdot \sin^2(2\Theta_0) + K_2^2 + 2K_2 \cdot K_3 \cdot \sin^2(\Theta_0) + K_3^2 \cdot \sin^4(\Theta_0)) \cdot R_0^2 \sin \Theta_0 dR_0 d\Theta_0 d\Phi_0 \\
 &= \dots = 0.155 \frac{J}{m} \cdot r_0 \quad (\text{equ.21})
 \end{aligned}$$

$$\begin{aligned}
 W_{\text{magn}_{\text{int}}} &\cong \int \frac{\mu_0}{2} \cdot |\vec{H}_{\text{int}}|^2 dV \\
 &= \int_0^{2\pi} \int_0^\pi \int_0^{r_0} \frac{\mu_0}{2} \cdot \frac{q^2 c^2}{r_0^8} \cdot (R_0^4 K_4^2 \cdot \sin^2(2\Theta_0) + r_0^4 K_5^2 - 2r_0^2 R_0^2 K_5 K_6 \sin^2 \Theta_0 + R_0^4 K_6^2 \cdot \sin^4 \Theta_0) R_0^2 \sin \Theta_0 dR_0 d\Theta_0 d\Phi_0 \\
 &= \dots = 2.5578 \cdot 10^{-29} \text{ Jm} \cdot \frac{1}{r_0} \quad (\text{equ.22})
 \end{aligned}$$

We see that the energy of the magnetic field contains a portion which is decreasing with  $r_0$  and an other portion which increases with  $r_0$ .

Summation of the equations 03, 21 and 22 will lead us to the total electric and magnetic energy of the electron as following:

$$W_{\text{tot}} \approx 1.408 \cdot 10^{-28} \text{ Jm} \cdot \frac{1}{r_0} + 0.155 \frac{\text{J}}{\text{m}} \cdot r_0 \quad \text{with} \quad W_{\text{tot}} = m_0 c^2 \quad (\text{equ. 23})$$

Because the speed of the charge-elements (as speed of light) is a pre-condition, we only receive one single equation with one unknown parameter. This equation (equ.23) is quadratic (if we replace the sign "≈" by a "=") and has the following both solutions:

$$r_{0,1} = 1.725 \cdot 10^{-15} \text{ m} \quad (\text{equ. 24a})$$

$$r_{0,2} = 5.267 \cdot 10^{-13} \text{ m} \quad (\text{equ. 24b})$$

Both of them could be able to explain the mass of the electron completely by the energy of its fields. A discussion of this result will now follow in chapter 4.

#### 4. Discussion of the results:

We got two different possible values for the radius of the electron – but which one is the real value with physical sense ?

Even though one of these both values is very similar to the classical radius of the electron, we want to make our decision by the means of a physical consideration, as following.

We remember the second size which we used before, the magnetic moment (see equations 12, 13 and 14). In the case of the electron as a non-rigid field-source, the magnetic moment has to be calculated as following:

$$\mu = \int \tilde{A}(\Theta_0, \Phi_0) \frac{\sigma(\Theta_0, \Phi_0)}{T} dA \quad (\text{equ. 25})$$

with  $\tilde{A}(\Theta_0, \Phi_0)$  and  $\sigma(\Theta_0, \Phi_0)$  same as in equations 11,12,13.

but  $T = \frac{\text{distance}}{\text{speed}} = \frac{2\pi r_0 \sin\Theta_0}{c} = \text{duration for circulation of the charge in each single conductor loop} \quad (\text{equ. 26})$

$$= \int_0^{2\pi} \int_0^\pi \pi r_0^2 \sin^2\Theta_0 \cdot \frac{q}{4\pi r_0^2} \cdot \frac{c}{2\pi r_0 \sin\Theta_0} \cdot r_0^2 \sin\Theta_0 d\Theta_0 d\Phi_0 = \frac{\pi}{8} q c r_0 = \frac{q\hbar}{2m} \quad (\text{equ. 27})$$

↑ shall be equal with Bohr's Magneton

$$\Rightarrow r_0 = \frac{4\hbar}{m\pi c} = 4.92 \cdot 10^{-13} \text{ m} \quad (\text{equ. 28})$$

This value is in clear contradiction with  $r_{0,1}$ , but it confirms  $r_{0,2}$ . It could not by accident, that the energy and the magnetic moment of the electron match to each other in such perfect manner and lead to the same value for the radius of the electron.

If we remember that the estimation of the field's energy (in equation 23) is a lower estimation, and in reality the energy is some percent larger, we see, that the electron's radius is a little bit smaller than  $r_{0,2}$  according to equation 24b.

Consequently we regard the result of equation 28 as the solution with physical sense, which is indeed different from the classical electron's radius. This result shows, that

the major part of the electron's energy is stored in its magnetic field and only the minor part of its energy is stored in its electrostatic field.

### Résumé:

Now we got the proof, that the mass of the electron can be theoretically deduced from the energy of its fields. We also see the way of this deduction, and furthermore we got a very first (rough) estimation of the electron's radius and the energy value of this special lepton.

If we put the equations 25, 28 and 23 together, we receive the field's energy:

$$W_{\text{tot}} \approx 7.655 \cdot 10^{-14} \text{ J} = 478 \text{ keV} \quad (\text{equ. 29})$$

This roughly determined value of the electron's mass is by about 6.5% smaller than the well known real value of 511keV, which confirms the sign " $\approx$ " for our lower estimation quite well. The speciality of our model is the fact, that we need one single (and very simple) assumption, namely: We regard the electron as a spherical gyrotor with all its charge gyrating on its surface, moving with the speed of light. And because of the prescription how to add velocities in the theory of relativity, all charge elements of the electron will move with the speed of light, from which system we ever look onto it. Thus the energy of the electron has to be the same in every system.

## **(5.) Continuative considerations**

### **(a.) Expand the model to all elementary particles**

The idea to calculate the mass of a particle from the energy of its causative interactions was now demonstrated on the example of the electron. It is desirable to expand this model to all basic elementary particles - such as leptons and quarks (and later to all known particles at all). If this would be possible, we could understand the nature of all elementary particles as sources of fields.

### **(b.) Transfer the model to quantum theory**

For a quantum theoretical approach we would have to replace the concept of interaction fields by interaction quanta (for instance like photons or W- or Z- bosons).

If these calculations in quantum theory could be done with high precision, than maybe one day we might see quantumelectrodynamical or quantumchromodynamical effects (for instance like vacuum polarisation) on the mass of a particle. For the electron, also the field of the weak interaction can be included in order to calculate the mass very exact – this would be a test of the model of the interaction- based understand of mass.

### **(c.) Enhance the precision of the calculation**

The imperfection of the precision of the here reported calculations is only about 6.5% with respect to the electron. The reason is the impreciseness of the iterative integration for the calculation of the magnetic field. But the trial to expand the model to other charged leptons (muon und tauon) displays such large impreciseness, that it is not yet sensible to present already numerical values just within this article here. But there is serious hope that an improvement of the mathematical exactness of the integration might lead us to the systematics of the electrically charged leptons one day.

**(d.) Test the relevance of weak and strong interaction**

This should bring us information about the electrically uncharged leptons, the neutrinos. The only causative interaction on which they participate is the weak interaction. According to the interaction- based explanation of mass, this should give them a small but existing rest mass.

An exact calculation of the neutrinos rest mass is only possible on the basis of quantum- chromodynamics (see point b.), because the calculation of weak interaction by itself needs interaction quanta (see Glashow- Weinberg- Salam- Theory, see for instance [SCH 97], [GRE 96]).

A very rough preliminary estimation of the order of magnitude of the neutrino's rest mass, could give us a feeling, whether this type of task might be rewarding or not. (The following numerical estimation shall not be misinterpreted as an exact calculation, but it only shall motivate to plan such a calculation.)

- comparison of the strength of the interaction by the means of coupling constants:

$$\text{electromagnetic interaction:} \quad \text{coupling constant} = \frac{1}{137.036} \approx 10^{-2}$$

$$\text{weak interaction:} \quad \text{coupling constant} \approx 10^{-5} \quad (\text{see also [GRO 89]})$$

(It is considered as negligible to deal with running coupling constants here.)

- The energy contained within the interaction behaves proportional with the square of the field strength and by that with the square of the coupling constants.

$$\text{energy} \propto \text{field strength}^2 \propto (\text{coupling} - \text{const.})^2$$

- From the ratio of the coupling constants we can draw conclusions to the amount of energy within the interactions:

$$\frac{E_{\text{weak}}}{E_{\text{electromagn.}}} \approx \frac{(10^{-5})^2}{(10^{-2})^2} = 10^{-6} \quad (\text{equ.30})$$

- Taking the finite range of the weak interaction into account, in opposite to the infinite range of the electromagnetic interaction, we know that equation 31 can only be a far upper limit of the electron- neutrino's energy, because the volume integral has to be calculated for a volume of only few  $(10^{-18} \text{ m})^3$ :

$$E_{\nu_e} \leq 10^{-6} \cdot E_e = 10^{-6} \cdot 511 \text{ keV} \quad (\text{equ. 31})$$

, where  $E_{\nu_e}$  = Energy ( resp. mass ) of the electron-neutrino  
 $E_e$  = Energy ( resp. mass ) of the electron

Annotation: The range of the weak interaction is known to result from the mass of the intermediative bosons ( $W^\pm, Z^0$ ) (see for instance [PAU 01]):

$$\text{range} \quad R \leq \frac{\hbar}{m_w c} \approx 2 \cdot 10^{-18} \text{ m} \quad (\text{equ. 32})$$

, where  $\hbar = h/2\pi$   
 $m_w$  = mass of the virtual intermediative boson  
 $c$  = vacuum light-speed

- From the very small range of the weak interaction we expect the electron-neutrino's mass to be less or perhaps much less than half an eV (compare equation 31):

$$E_{\nu_e} \lesssim 0.5 \text{ eV} \quad (\text{equ. 33})$$

On this background it seems rather likely that the rest mass of the electron- neutrino will be found in the order of magnitude of few milli-eV. This also coincides with the demands of several cosmological models which investigate the critical density of the universe ([HIL 96]) and also with neutrino- oscillations that can only be explained if the neutrino has an existing rest mass. The Super- Kamiokande Collaboration experimentally determines this rest in the range of about  $\frac{1}{2} \dots 6$  milli-eV ([KAM 98]), which is quite well in agreement with my estimation of few milli-eV.

This estimation of magnitude looks suitable to encourage to plan exact calculations for the determination of the neutrino's restmasses by the usage of the model of the interaction- based understanding of mass. But we should put charged and neutral currents corresponding to  $W^\pm$ -bosons and to  $Z^0$ -bosons (following the Glashow- Weinberg- Salam- Theory) into the model as far as neutrinos are capable to exchange these bosons (see also [SCH 97]).

Integration of the density of energy over the space which is reached by the finite range of these bosons should lead to the masses of the neutrinos.

**(e.)** Explanation of relativistic mass enhancement for fast moving particles

This effect should follow from the contraction of the particles length (id est the shape of its surface) within the direction of movement, which alters the field's volumina. The decreased volume causes an increase of the field's energy just at the locations with high field strength. In the extreme case of the speed of the particle converging against the speed of light, the particle's volume converges against zero and with that, the particle's mass converges against infinite. Hopefully it will be possible, to explain the complete relativistic mass enhancement on the basis of the relativistic length contraction.

**(f.)** How about any deviation of Coulomb's law from the behaviour of  $\frac{1}{r^2}$  ?

(See shielding of the electron's electrical charge by itself because of vacuum polarisation.)

Coulomb's law is considered as verified down to distances much smaller than any of the values of the electron's radius mentioned above, no matter whether we take the classical value of  $2.8 \cdot 10^{-15} m$  or our value of  $4.9 \cdot 10^{-13} m$ . Namely: Up to now there is not any inner structure of the electron found down to a length scale of  $10^{-18} m$ .

Under this context it becomes necessary to control whether a hollow sphere, charged on surface, follows the same behaviour in scattering like a punctiform electron. When the centres of two such spheres come close to each other, their surface elements do the same. So we expect that hollow spheres display the same scattering- behaviour as punctiform charges.

The commonly known fact of the alteration of the coupling constant " $\alpha$ " for extremely short distances arises the question about deviations from the simple homogenous distribution of charge on the electrons surface.

**(g.)** Relation to other modern theories

Another approach to connect gravitation with the other fundamental interactions originates from the institute "California Institute of Physics and Astrophysics" (see [CIPA 03]).

Same as in my work, Higgs- fields and Higgs- bosons are not needed at all. In publications like [HAI 02], the nature of mass is ascribed to a so called “zitterbewegung” (=quivering movement) which leads to mass because of an application of stochastic electrodynamics – which interestingly is done (same as in my theory) within a semiclassical model. This “Zitterbewegung” describes the movement of a punctiform shaped charge within a sphere whose radius is that of the particle. Also same as in my model, the movement of the charge element is going with the speed of light.

The main differences between their model and mine are the followings:

- a. In [HAI 02] the speed of light is taken as speed of movement for the charge without any reason; in my work the speed of the charge’s movement is coming inevitably from the calculations as the speed of light, because with different speed it would be impossible that the electron could achieve its mass and its magnetic moment at the same time.
- b. In the work of [HAI 02] the movement of the charge is regarded as the stochastic movement of one single element of charge. In my work, the charge of the particle is splitted into infinitely many elements of infinitesimally small size and charge, all of them moving along well-regulated paths. Summation over all infinitesimal charge elements will lead to the same total current as in the model of [HAI 02]. Both models in common have the fact that the movement is restricted by Heisenberg’s relation of uncertainty.
- c. According to CIPA the frequency of the charges movement is understood stochastically with a limit at the value of the Planck- frequency.  
In my work the frequency of the charges movement is a result of the circulation at the curve along the equator, which defines a lower frequency- limit of

$$\omega_u = \frac{c}{r} = \frac{2.997 \cdot 10^8 \frac{m}{s}}{4.92 \cdot 10^{-13} m} = 6.09 \cdot 10^{20} Hz \text{ (angular frequency, lower limit for the charge elements gyrating around the equator)}$$

The only thing which remains unclear within the stochastic movement of the charge is how the electron comes to its magnetic moment.

In most of all further consequences there are rather extensive similarities between the CIPA point of view and mine.

#### (h.) Connection between Gravitation and the three causative interactions

If it is possible to explain all mass by the energy of fields, and to regard the particles as sources of fields, gravitation can be understood as a consequence of all other three interactions in the following way:

Electromagnetic, weak and strong interaction can be regarded as “causative” interactions, which produce fields and from these produce a mass connected to the energies of these fields. This mass will then cause a bending of space-time according to Einstein’s theory of relativity (see for instance [GOE 96]), which corresponds to the formation of gravitation. From this point of view we can understand gravitation as a consequence originating from the other “causative” interactions. So we can regard gravitation as the “consecutive” interaction.

For single elementary particles the “causative” interactions dominate compared to the “consecutive” interaction of gravitation. But if very many elementary particles stick together (like in hadrons or in atoms or in objects of our everyday life), the “causative” interactions compensate one another within very tight space (with fields that produce

binding-energy), so that the sum of the “causative” interactions will have no further consequence but only keeping objects (or atoms) within their shape. On long distance range, only bending of space-time remains remarkable which is important for the motion of the objects as being known from classical physics. (Nevertheless it should not be forgotten, that in the universe there are objects with gravity dominating the other interactions: the black holes ([GOE 96])).

In this sense the interaction- based explanation of mass makes a connection between the three causative interactions and the consecutive interaction of gravitation.

## **6. Literature**

- [ABE 71/81] All books of Electrodynamics , as for instance
- “Bergmann- Schäfer: Lehrbuch der Experimentalphysik“  
Band 2: “Elektrizität und Magnetismus“ by H.Gobrecht  
z.B. 6.Aufl., W de Gruyter Verlag, 1971, ISBN 3-11-002090-0
  - “Klassische Elektrodynamik“ by John David Jackson  
W de Gruyter Verlag, 1981, ISBN 3-11-007415-X
- [BRO 79] “Taschenbuch der Mathematik“  
by I.N.Bronstein and K.A.Semendjajew  
18.Auflage, Verlag Harri Deutsch 1979, ISBN 3-87144-016-7
- [CIPA 03] work done by CIPA,  
California Institute for Physics and Astrophysics Research  
found at <http://www.calphysics.org/>
- [COD 98] “CODATA Recommended Values of the Fundamental Physical Constants:1998” by Peter J. Mohr and Barry N. Taylor  
Review of Modern Physics, Vol.72, No.2, page 351, April 2000
- [EIN 65] “Grundzüge der Relativitätstheorie“  
by Albert Einstein, 4.Auflage im Vieweg- Verlag, 1965
- [FEY 88] “QED – Die seltsame Theorie des Lichts und der Materie.“  
by Richard P. Feynman, Verlag R.Piper, 1988, ISBN 3-492-03103-X
- [FEY 91] "Feynman Vorlesungen über Physik"  
by Richard P. Feynman, Robert B.Leighton, Matthew Sands  
2.Auflage, R.Oldenbourg- Verlag 1991, ISBN 3-486-22058-6  
especially part 2, chapter 28 "Elektromagnetische Masse"
- [FRA 99] “Teilchen und Kerne“ by H.Frauenfelder and E.M.Henley  
4. Auflage, R.Oldenbourg Verlag, 1999, ISBN 3-486-24417-5
- [GOE 96] "Einführung in die spezielle und allgemeine Relativitätstheorie"  
by Hubert Goenner Spektrum, Akademischer Verlag, 1996  
ISBN 3-86025-333-6

- [GRE 96] "Gauge Theory of Weak Interactions" third edition  
by W. Greiner and B. Müller, Springer-Verlag, 2000  
ISBN 3-540-67672-4
- [GRO 89] "Die schwache Wechselwirkung in der Kern-, Teilchen- und Atomphysik"  
by K. Grotz and H.V. Klapdor  
Verlag B. G. Teubner, Stuttgart 1989, ISBN 3-529-03035-7
- [HAI 02] "Update on an Electromagnetic Basis for Inertia, Gravitation, the  
Principle of Equivalence, Spin and Particle Mass Ratios"  
by Bernhard Haisch, Alfonso Rueda, L.J. Nickisch and Jules Mollere  
to be published: Conference Proceedings of the American Institute of  
Physics found at [arXiv:gr-qc/0209016v1](http://arxiv.org/abs/gr-qc/0209016v1) on Sept-5-2002
- [HIG 64] "Broken Symmetries and the Masses of Gauge Bosons"  
by Peter W. Higgs, Phys.Rev.Lett. Vol.13, No.6, year 1964
- [HIL 96] "Elementare Teilchenphysik" by Helmut Hilscher  
Verlagsgesellschaft Friedr. Vieweg & Sohn, Braunschweig, 1996,  
ISBN 3-528-06670-9
- [KAM 98] "Evidence for oscillation of atmospheric neutrinos"  
The Super-Kamiokande Collaboration  
Paper (submitted to Phys. Rev. Lett.),  
found in March-14-2004 in internet at:  
<http://www-sk.icrr.u-tokyo.ac.jp/doc/sk/pub/nuosc98.submitted.pdf>
- [KOH 85] "Praktische Physik" (especially part 2)  
by F. Kohlrausch, for instance 23. Auflage  
Verlag B.G. Teubner, Stuttgart 1985, ISBN 3-519-13002-5
- [KÖP 97] "Einführung in die Quanten - Elektrodynamik"  
by G. Köpp and F. Krüger  
B.G. Teubner Verlag, Stuttgart 1997, ISBN 3-519-03235-X
- [PAU 01] "ONLINE- Skript: Teilchen und Kerne" an der Universität München  
by S. Paul and W. Weise, Version vom 20.6.2001  
found at : <http://axp01.e18.physik.tu-muenchen.de/~skript/>
- [PER 91] "Hochenergiephysik" by Donald H. Perkins  
Addison- Wesley Verlag, 1991, ISBN 3-89319-111-9
- [SCH 97] "Neutrino-Physik" by N. Schmitz  
Verlag B.G. Teubner, Stuttgart 1997, ISBN 3-519-03236-8
- [SMI 81] "Lehrgang der höheren Mathematik" by W.I. Smirnow,  
for instance 15. Aufl. im VEB "Deutscher Verlag der Wissenschaften"  
Lizenz-Nr. 206.435/81/81